



**SCHOOL OF BUSINESS AND LAW
FINANCE AND ACCOUNTING DEPARTMENT**

**BANKING AND FINANCE
PROGRAM HANDBOOK**

AY 2023-2024



Table of Content

<u>A Massage from the Dean of School of Business and Law</u>	3
<u>A Massage from the Chair of Finance and Accounting</u>	4
<u>Dar Al-Hekma University Vision and Mission</u>	5
<u>Dar Al-Hekma University Values</u>	6
<u>Dar Al-Hekma University Strategic Goals</u>	7
<u>School of Business and Law Mission</u>	8
<u>Banking and Finance Program Mission</u>	9
<u>Banking and Finance Program Overview</u>	10
<u>Banking and Finance Program Staff & Faculty</u>	11
<u>Banking and Finance Program Goals</u>	12
<u>Banking and Finance Program Graduate Attributes</u>	13
<u>Banking and Finance Program Learning Outcomes</u>	14
<u>Banking and Finance Program Significance of the Program</u>	15
<u>Banking and Finance Program Plan of Study</u>	16
<u>Banking and Finance Program Flowchart of the Plan of Study</u>	17
<u>Banking and Finance Program Course Descriptions</u>	18
<u>Banking and Finance Program Tracks</u>	26
<u>Banking and Finance Program Career</u>	27
<u>Banking and Finance Program Key Achievements</u>	28
<u>Banking and Finance Program Clubs</u>	29
<u>Banking and Finance Program Admission Requirements and Tuition Fees</u>	30



A Message from the Dean of School of Business and Law

Dear Students,

Welcome to the Banking and Finance Program at Dar Al-Hekma University!

As the Dean of the School of Business and Law, I am thrilled to have you as part of our vibrant and dynamic academic community. The field of banking and finance is ever-evolving, and by choosing to pursue this program, you have taken the first step towards a rewarding and impactful career in the financial industry.

Our commitment to providing a comprehensive and rigorous education in banking and finance is unwavering. We take pride in preparing our students to meet the demands of an ever-evolving financial landscape through a curriculum that emphasizes both theoretical understanding and practical application. Our alumnae are an excellent proof of the quality we offer. Many of our alumna are employed in leading positions in the market and others went on to pursue their studies in well-known universities abroad.



Throughout your time in the Banking and Finance Program, you will have the opportunity to explore a broad range of topics, including financial markets, investment analysis, corporate finance, banking operations, risk management, and business data analysis. Additionally, you will have access to cutting-edge resources and technologies that will enhance your understanding of contemporary financial issues and enable you to develop practical solutions to real-world challenges. As you embark on this academic journey, I urge you to approach your studies with a spirit of curiosity, diligence, and perseverance. Take full advantage of the opportunities for experiential learning, internships, and industry engagement that the program offers. These experiences will not only complement your classroom learning but also deepen your understanding of the practical applications of banking and finance.

Furthermore, I encourage you to actively participate in the academic and extracurricular activities available within the School of Business and Law and across the university. Engaging with your peers, professors, and professionals in the field will enrich your educational experience and expand your professional network, setting the stage for future success.

Remember that the education and experiences you gain here will prepare you to make a positive impact in the financial sector. Your dedication and hard work will not only set the stage for a successful career but also empower you to contribute to the economic development and financial well-being of our country.

Once again, welcome to the Banking and Finance Program at Dar Al-Hekma University. I look forward to witnessing your growth and achievements during your time with us.

Inass Salamah Ali, Associate Professor
Dean/School of Business & Law
Dar Al-Hekma University



A Message from the Chair of Finance and Accounting Department

Dear Students,

Welcome to the Banking and Finance program in Dar Al-Hekma university.

As a chair of the Finance and Accounting Department and the Director of the Banking and Finance program, I am delighted to be collaborating with you to support your educational journey.

The Banking and Finance program is equipped you with the knowledge, skills, and experiences required to succeed in your future professions and make valuable contributions to the banking and financial sector in Saudi Arabia, that though our robust curriculum. Our curriculum was designed in collaboration with top national and international universities.

Developed by HASS School of Business, University of California Berkeley, USA and tailored specifically to the Saudi market by King Fahd University of Petroleum and Minerals.

I am fully committed to supporting your success, assisting your achievements, and allocating time for extra-curricular activities, side by side with your classes. In exchange, I expect you to work hard in your class and to participate in the department's various activities and look for opportunities to give back to our community.

I'm excited to follow your development and successes as you start along this fascinating financial career path.

Sincerely
Dr. Layla Khoja,
Assistant Professor
Chair of the Finance and Accounting department
Director of the Banking and Finance program





Dar Al-Hekma University

Vission & Mission

Vision

"A university that takes the lead in education, development, and creativity to positively impact the society"

Mission

"Graduating leaders and entrepreneurs who embody the values of the university through providing an educational environment that encourages development, creativity, scientific research and community service".

Dar Al-Hekma University

Values



Quest for Excellence: Dar Al-Hekma strives to promote and pursue excellence in all forms and ways, be it through curricular or extra-curricular pursuits; personal or institutional; individual or team effort.

Vision for the Future: Dar Al-Hekma, as a visionary community, values creative and innovative learning that preserves, protects and advances the human, social and physical environment, while building the knowledge base to assure a sustainable future for all.

Appreciation for Knowledge: Dar Al-Hekma values knowledge attained through diverse means of teaching and learning methodology and honors the sources of knowledge.

Creativity and Innovation: Dar Al-Hekma embraces new ideas and encourages innovation with entrepreneurial spirit.

Service to Our Community: Dar Al-Hekma values its obligations to the larger community and ensures through the design and delivery of all its academic programs and services that the community is well served



Dar Al-Hekma University

Strategic Goals





School of Business and Law

Mission

"To graduate professionals equipped with knowledge, skills, and values in the areas of Business, Law, and International Relations within an academic environment that encourages scientific research and community engagement"





Banking and Finance Program

Mission

To graduate professionals equipped with knowledge, skills, and values in the areas of banking, investment and finance within an academic environment that encourages scientific research and community engagement"





Banking and Finance Program

Overview

The Banking and Finance Program at Dar Al-Hekma University offers a unique well-structured curriculum which prepares students to earn a bachelor's degree in banking and finance and succeed in the dynamic financial world. The first in the region to offer an Islamic finance track, the program is keen on preparing young professionals for this fast-growing field. The students in the program start with core business courses to establish a strong foundational understanding of the business environment. Specialization courses are taught in the junior and senior years providing students with a deeper understanding of specialized areas such as Investment Banking, Corporate Finance, Risk Management of Financial Markets and Institutions, and Financial Modeling. Combining their academic and financial expertise gained through many years of experience in the industry, our faculty expose students to the realities of the market and work on enhancing their knowledge, critical thinking, and skills.

The program aims at bridging the gap between theory and practice by offering many opportunities of exposure to real life practices through educational field trips, and presentations and workshops by inspiring industry leaders, and guest speakers. Students also participate in worldwide competitions, such as the CFA Research Challenge. There is a high demand for our students in the financial job market which offers many career paths and opportunities.



Banking and Finance Program Staff and Faculty Members

Dr. Inass Ali

Dean of the School of Business and Law
Associate Professor
Email:
Phone: (012) - 6303333 Ext. 387

Dr. Layla Khoja

Chair of Finance and Accounting department
Director of Banking and finance program
Assistant professor
Email: lkhoja@dah.edu.sa
Phone: (012) - 6303333 Ext. 857

Dr. Karima Saci

Assistant professor
Email: ksaci@dah.edu.sa
Phone: (012) - 6303333 Ext. 290

Dr. Mohammed Al Malak

Assistant Professor
Email: mmallak@dah.edu.sa
Phone: (012) - 6303333 Ext. 169

Ms. Saida Khalifa

Lecturer
Email: skhalifa@dah.edu.sa
Phone: (012) - 6303333 Ext. 180

Ms. Abeer Harharah

Teaching Assistant
Email: aharharah@dah.edu.sa
Phone: (012) - 6303333 Ext. 759

Banking and Finance Program

Goals



1. Expand the banking and finance program in alignment with the job market needs.
2. Enrich the banking and finance profession by graduating qualified professionals.
3. Increase research opportunities in the area of banking and finance.
4. NCAAA accreditation for the banking and finance program.
5. Promote the banking and finance profession in the community.

Banking and Finance Program

Graduate Attributes

Our Graduates will have the following attributes upon graduation:

- Knowledgeable of the broad conceptual and theoretical aspects of banking and finance.
- Well informed of the trends and dynamics of the financial industry.
- Effective problem solvers in different professional situations.
- Capable of making effective decisions.
- Persuasive oral and written communicators.
- Committed to ethical practices and social responsibility.
- Independent and collaborative team players.





Banking and Finance Program

Learning Outcomes

KNOWLEDGE

- Explain concepts, principles, and practices related to business.
- Identify fundamentals and theories related to banking and finance from both the conventional and Islamic perspectives.
- Recognize the implications of domestic and foreign influences on financial markets and financial institutions, from the general as well as the Islamic perspective.

SKILLS

- Demonstrate the ability to critically analyse, manage, and make decisions to deal with the challenges and complexities of the national and global business environments.
- Use techniques and methods of inquiry to collect and interpret data to provide information that would support strategic decisions.
- Demonstrate effective written and oral communication skills.
- Apply appropriate techniques to evaluate various scenarios related to corporate finance, investment, commercial and Islamic banking, and risk management with emphasis on the Islamic perspective.
- Demonstrate analytical and problem-solving skills to make financial decisions.

VALUE

- Demonstrate an understanding of professional, ethical, legal, secure, and social issues and responsibilities.
- Work independently and/or as part of a team.



Significance of the Banking and Finance Program

Significance of the Finance and Banking Program:

- The banking and finance curriculum combine theory and concepts with practical skills needed in the job market.
- The program associates itself with the industry through strong links with prominent employers and prepares its graduates to meet the requirements of the industry.
- The curriculum was designed in collaboration with top national and international universities and developed by the Hass School of Business at the University of California Berkeley, USA and tailored specifically to the Saudi market by King Fahd University.
- The program is accredited by the National Commission of Academic Accreditation and Assessment (NCAAA).
- The faculty of the program are a mix of highly qualified international and national scholars who hold degrees from reputable world-class universities.
- The programme is aligned with 3 papers exemptions with ACCA which are: Business and Technology (BT), Management Accounting (MA), and Financial Accounting (FA).





Banking and Finance Program

Plan of Study

Rank: Year 1 - Semester 1 - Freshmen		
BBUS 1301	Introduction to Business	3
MATH 1301	College Algebra	3
BMKT 1301	Principles of Marketing Management	3
COMM 1301	Communication Skills I	3
ICTC 1301	Information and Communication Technology	3
ARABXXXX	Arabic Studies	3
TOTAL		18

Rank: Year 1 - Semester 1 - Freshmen		
BACC 1301	Principles of Financial Accounting	3
BMGT 1301	Principles of Management	3
BBIS 1201	Principles of Microeconomics	2
MATH 1303	Calculus	3
BBIS 1301	Business Information Systems	3
ISLS XXXX	Islamic Studies	3
TOTAL		17

Rank: Year 2 - Semester 1 - Sophomore		
BACC 2301	Principles of Managerial Accounting	3
BECO 2301	Principles of Macroeconomics	3
BMGT 2302	Human Resource Management	3
BSTA 2301	Statistics for Business	3
ARTS XXXX	Arts and Design	2
COMM 1302	Communication Skills II	3
TOTAL		17

Rank: Year 2 - Semester 2 - Sophomore		
BBUS 2302	Quantitative Analysis for Management	3
BFIN 2302	Financial Management	3
BMGT 2301	Principles of Organizational Behavior	3
ARABXXXX	Arabic Studies	3
LOGC 1201	Logic and Problem Solving	2
XXXX XXXX	Required General Ed Electives (HUMN, NASC, SBSC)	3
TOTAL		17

Rank: Year 3 - Semester 1 - Junior		
BMGT 3301	International Business Management	3
BMGT 3201	Legal Environment of Business	2
BNFN 3303	Investment Analysis and Portfolio Management	3
BNFN 3302	Commercial Bank Management	3
BBUS 3302	Research Methodology	3
ENTR 3301	Entrepreneurship and Design Thinking	3
TOTAL		17

Rank: Year 3 - Semester 2 - Junior		
BMGT 3304	Strategic Management	3
BNFN 3307	Islamic Banking and Finance	3
BNFN 3305	Risk Management of Financial Markets and Institutions	3
EMOI 1201	Emotional Intelligence	2
ISLS XXXX	Islamic Studies	3
XXXX XXXX	Required General Ed Electives (HUMN, NASC, SBSC)	3
TOTAL		17

Rank: Year 4 - Semester 1 - Senior		
BBUS 4301	Business Ethics and Social Responsibility	3
BNFN 4301	Corporate Finance	3
XXXX XXXX	School/Program Elective	3
BBBF 1101	Basic Body and Brain Fitness	1
ISLS XXXX	Islamic Studies	3
XXXX XXXX	Free Elective	3
TOTAL		15

Rank: Year 4 - Semester 2 - Senior		
BNFN 4309	Investment Banking	3
BNFN 4304	Financial Policy	3
BNFN 4303	Internship: Banking and Finance	3
XXXX XXXX	Free Elective	3
TOTAL		12

130

Program Elective		CH
BNFN 3306	Islamic Accounting	3
BNFN 4306	Selected Topics in Banking and Finance	3
BNFN 4307	International Finance	3
BNFN 4308	Real Estate Management	3
BFIN 3301	Financial Modelling	3



Banking and Finance Program Flowchart of the Plan of Study

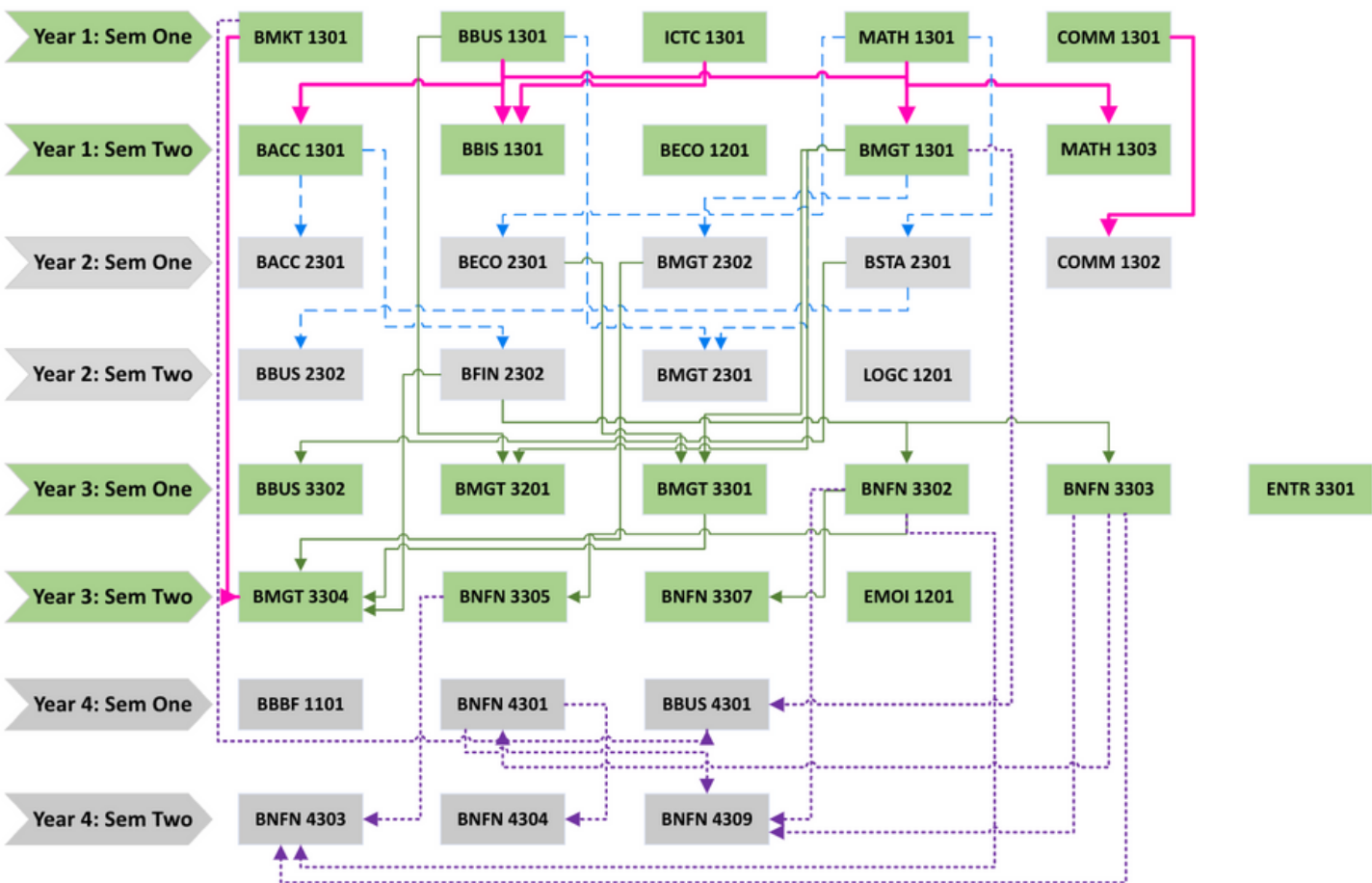



Banking and Finance Program

Course Descriptions

Year 1: Semester One

BBUS 1301: Introduction to Business (3)

Prerequisite(s): None

This course gives an understanding of the aims of business activity and overview of the environment in which business works. All course topics are covered in relation to both the international business environment, in general, and to Saudi business environment, specifically. It outlines major local, regional and international groups within and outside business and their influences on business organizations. It also addresses the different forms of business organizations. The course also covers the main components of a typical business plan.

MATH 1301: College Algebra (3)

Prerequisite(s): None

This course provides a broad-based foundation in algebra which emphasizes important concepts and skills covering the concepts of algebra, such as polynomials, solving equations (linear and nonlinear) and inequalities, and exploring functions and their graphs. Students are introduced to exponential and logarithmic concepts and equations. Real world applications are presented within the course content. Technology is integrated into this course by using a graphing calculator.

BMKT 1301: Principles of Marketing Management (3)

Prerequisite(s): None

This course focuses on marketing principles and the basic marketing decisions facing a firm. It emphasizes the assessment and understanding of the marketplace, marketing strategies, including segmentation, targeting and positioning, product, price, place, and promotional strategies. The course also provides a framework for understanding and implementing these strategies in the local market.

COMM 1301: Communication Skills I (3)

Prerequisite(s): ENRM 1301

This course focuses on the development of intellectual viewpoints, class discussions and debates. The course emphasizes the writing skills needed to produce different types of essays, demonstrating key rhetorical devices and correct citations. It highlights the processes needed for essay development.

ICTC 1301: Information and Communication Technology (3)

Prerequisite(s): None

The course introduces the basic computer knowledge and skills required in the everyday professional and personal use of computers. It focuses on the use of twenty first century technology in the workplace. The course emphasizes computer essentials, word processing, spreadsheets, and presentation software. It further provides a foundation for the use of the Internet, World Wide Web, online communication tools, information security, and latest trends for computers and information.



Banking and Finance Program

Course Descriptions

Year 1: Semester Two

BACC 1301: Principles of Financial Accounting (3) **Prerequisite(s): BBUS 1301**

This course provides students with the fundamentals of financial accounting. It explains accounting concepts, theory and procedures for proprietorships, partnerships and corporations. The course covers the accounting cycle as reflected in the sequence of accounting procedures used to record, classify and summarize accounting information in financial reports. All these topics and other advanced topics of financial accounting are discussed in relation to the Saudi business environment.

BMGT 1301: Principles of Management (3) **Prerequisite(s): BBUS 1301**

This course covers the fundamentals of the management process. The basic functions of management: planning, organizing, directing and controlling are covered. Also included are social responsibilities, political influences and ethical considerations as they affect the management of organizations. The course also introduces the students to international business, production, communications and decision making in terms of management activities.

BECO 1201: Principles of Microeconomics (2) **Prerequisite(s): None**

This course introduces the basic economic concepts related to individual decision makers in the economy: households, businesses and governments. It focuses on the definition of economic problems and market systems and addresses factors of production and public expenditures issues. The course analyzes consumer and firm behaviors in different market structures.

MATH 1303: Calculus (3) **Prerequisite(s): MATH 1301**

This course provides an introduction to the use of calculus in some of the basic quantitative methods for business and social sciences. It emphasizes computational skills, ideas, and problem solving. It also introduces the method of least square and regression to model real-life situations and uses the concepts of differentiation and integration in business applications.

BBIS 1301: Business Information Systems (3) **Prerequisite(s): BBUS 1301 + ICTC 1301**

This course provides an overview of information systems (IS) and information technologies (IT) functions and challenges in different organizations and institutions. It presents managerial and organizational views of how information, communication and office technologies function in today's corporate world. It also introduces the technical environment of a business area and the different types of Information Systems used in the various organizational levels.



Banking and Finance Program

Course Descriptions

Year 2: Semester One

BACC 2301: Principles of Managerial Accounting (3)

Prerequisite(s): BACC 1301

This course provides an overview of the fundamentals of managerial accounting, with emphasis on the accumulation and usage of cost data. It also covers accounting systems, decision making, cost analysis, budgeting, management evaluation and control.

BECO 2301: Principles of Macroeconomics (3)

Prerequisite(s): MATH 1301

This course introduces macroeconomic analysis related to economic relationships. It covers national income accounting and determination, business cycles, aggregate demand, aggregate supply, inflation, unemployment, fiscal and monetary policies, money and banking, economic growth and development, and international trade. It focuses on the characteristics of the Saudi business environment in business operations.

BMGT 2302: Human Resource Management (2)

Prerequisite(s): BMGT 1301

This course introduces the field of human resources management and its main functions. It also familiarizes the students with the strategic role of human resources management in achieving organizations competitive advantage. The emphasis is on the main success measures for human resource activities, job analysis and design, recruitment and selection, performance and evaluation management, training and development, and career planning.

BSTA 2301: Statistics for Business (3)

Prerequisite(s): MATH 1301

This course aims at providing the necessary tools to analyze statistical information critically. It introduces concrete examples handling data sets and using standard techniques for displaying, summarizing and analyzing data. The course also covers business applications using statistical inference and hypothesis testing techniques for business problem-solving and decision-making.

COMM 1302: Communication Skills II (3)

Prerequisite(s): COMM 1301

This course reinforces critical reading and academic texts analysis. It focuses on advanced writing skills towards the development of different types of essays using APA style. The course emphasizes writing an extended argumentative essay.



Banking and Finance Program

Course Descriptions

Year 2: Semester Two

BBUS 2302: Quantitative Analysis for Management (3)

Prerequisite(s): BSTA 2301

This course provides an overview of operations research/ management science methods and their role in decision-making. The emphasis is on problem formulation and managerial interpretation. The course further emphasizes how managers can use this approach to design and control business processes to increase profitability and decrease costs for the organization. It also introduces quantitative procedures through situations that include both problem formulation and technique application integrated with personal computer software.

BFIN 2302: Financial Management (3)

Prerequisite(s): BACC 1301

This course introduces the basic theories, concepts and analytical techniques in Financial Management. It focuses on goals, objectives and functions of the financial manager as well as analysis of financial statements. It emphasizes on financial assets valuation and making long term investments and financing decisions particularly decisions related capital structure and capital budgeting. All topics are discussed with reference to the Saudi Market

BMGT 2301: Principles of Organizational Behavior (3) Prerequisite(s): BBUS 1301 + BMGT 1301

This course focuses on understanding human behavior in organizational settings. It emphasizes the causes and consequences of human behavior in organizations. It covers the effects of the organizational structure on the individual, the reward and leadership process, and the impact of managerial effectiveness on the organization. The course also provides a framework for understanding and implementing management functions involved in strategic planning and programming.

LOGC 1201: Logic and Problem Solving (2)

Prerequisite(s): None

This course introduces fundamentals of logic and techniques to enhance the skills of problem solving. It covers the properties of number system, methods of reasoning and set operations, counting and probability. It focuses on basic elements of logic with emphasis on constructing truth tables for different statements to produce logical conclusions.



Banking and Finance Program

Course Descriptions

Year 3: Semester One

BMGT 3301: International Business Management (3) Prerequisite(s): BMGT 1301 + BECO 2301

This course focuses on the nature and scope of international business and introduces the three environments in which international business managers must operate. It also provides an understanding of domestic, international, and foreign environments. It addresses the concepts of international business in local market conditions.

BMGT 3201: Legal Environment of Business (2) Prerequisite(s): BBUS 1301 + BMGT 1301

The course provides essential information concerning the legal environment in which businesses operate. It introduces legal concepts that affect business activities with emphasis on legal reasoning and problem-solving skills that can be applied in a business context. All the aspects of law covered in this course are examined from both international and Saudi law perspectives.

BNFN 3303: Investment Analysis and Portfolio Management (3) Prerequisite(s): BFIN 2302

This course focuses on the skills and competencies necessary for understanding, analyzing and applying the concepts and theories of investment in the Business environment. It provides an understanding of the return generating process of assets, including stocks and bonds. In addition, it details how various assets can be combined in efficient portfolios within the mean variance framework.

BNFN 3302: Commercial Bank Management (3) Prerequisite(s): BFIN 2302

This course introduces the management theory and practice relevant to banking institutions. It focuses on the analysis of commercial banks' financial statements and performance. It assesses the asset liability management strategies applied in commercial banks. It also evaluates the management strategies of different uses and sources of funds in commercial banks. The course emphasizes on the Saudi Commercial Banking practices and laws.

BBUS 3302: Research Methodology (3) Prerequisite(s): BSTA 2301

This course provides an overview of the nature of business and management research. It introduces the fundamental tools of research methodology. It also includes training in the areas of primary and secondary data collection and qualitative and quantitative methods of organizing data and utilization of research findings.

ENTR 3301: Entrepreneurship and Design Thinking (3) Prerequisite(s): None

This course introduces the concept of entrepreneurship, nature of enterprise and role of the entrepreneur. It emphasizes the theoretical and practical perspectives of the entrepreneurship process. The course also explores other aspects of entrepreneurship including the development and evaluation of business plans and the presentation and pitching to the business investors.



Banking and Finance Program

Course Descriptions

Year 3: Semester Two

BMGT 3304: Strategic Management (3) Prerequisite(s): BMGT 2302 + BMGT 3301 + BFIN 2302 + BMKT 1301

This course provides an overview of strategic management concepts and theories, and their importance to the organization, industry and society. It covers the analyses, decisions and actions an organization undertakes in order to create and sustain competitive advantage. It presents an insight into the successful operation of an organization in a complex global economy. This course addresses these operational issues in the Saudi business environment.

BNFN 3305: Risk Management of Financial Markets and Prerequisite(s): BNFN 3302 Institutions (3)

This course provides an understanding of the process of financial intermediation. It describes the role of financial institutions and financial markets in the process of capital formation in the economy. It also provides a deep understanding of how to identify, measure and manage risks in financial institutions. The focus is on interest rate risk, market risk, credit risk, foreign exchange risk and liquidity risks. The courses centers around the Saudi business environment.

BNFN 3307: Islamic Banking and Finance (3) Prerequisite(s): BNFN 3302

This course aims to introduce the main principles of Islamic banking and finance. It analyzes the difference between Islamic and conventional banking models. This course additionally focuses on major Islamic products and services offered by Islamic banks, economics of profit sharing, operations of Islamic banking, and operations of Islamic insurance. All topics are discussed in relation to the Saudi business environment.

EMOI 1201: Emotional Intelligence (2) Prerequisite(s): None

This course focuses on the key concepts of Emotional Intelligence. It emphasizes the importance and benefits of Emotional Intelligence. It also raises awareness about the role of competencies and skills in an individual's career.



Banking and Finance Program

Course Descriptions

Year 4: Semester One

BBUS 4301: Business Ethics and Social Responsibility (3) Prerequisite(s): **BMGT 1301 + BMKT 1301**

This course introduces ethical issues and dilemmas which arise in business contexts. It provides ethical concepts and frameworks that are relevant to resolving business problems. The course covers moral principles in business, ethical dilemmas and issues facing individuals and organizations, and safeguards to maintain ethics in business.

BNFN 4301: Corporate Finance (3) Prerequisite(s): **BNFN 3303**

This course discusses the goals of the financial manager and presents the analytical methods and practices of modern financial management. It addresses in more depth, various financial management topics and issues. Major finance concepts and theories are presented together with their applications. All these topics are discussed in relation to the Saudi business environment.

BBBF 1101: Basic Body and Brain Fitness (1) Prerequisite(s): **None**

This course focuses on body and brain fitness methods to gain values and integrity. The course analyzes the basic fundamentals and techniques used in a particular physical and/or mental activity. Activities vary from semester to semester.



Banking and Finance Program

Course Descriptions

Year 4: Semester Two

BNFN 4309: Investment Banking (3) Prerequisite(s): BNFN 3302 + BNFN 3303 + BNFN 4301

This course introduces the concepts and scope of investment banking. It focuses on the primary functions of investment banking such as mergers and acquisitions (M&A), IPO, leveraged buyouts (LBO) and corporate restructuring and the different valuation methods. It also covers ethical issues and the regulatory framework of investment banking.

BNFN 4304: Financial Policy (3) Prerequisite(s): BNFN 4301

This course introduces the application of the concepts, skills, tools and techniques acquired in finance and other business courses to real finance problems. The course focuses on setting appropriate financial strategies and policies. It mainly utilizes the case method of instruction. Prerequisites: BFN 4301 Corporate Finance.

BNFN 4303: Internship: Banking and Finance (3) Prerequisite(s): BNFN 3302 + BNFN 3303 + BNFN 3305

This course provides the opportunity to gain knowledge through actual job experience in the profession. Internships represent job experience which is aimed at supplementing the classroom learning process and to allow familiarization with real world experiences related to the Banking and Finance profession. The internship program period covers 180 hours of working experience applied at a bank or a related financial institution locally or internationally.

Banking and Finance Program Tracks



Islamic Finance Track

Islamic finance has been introduced as a track in the Banking and Finance Program. to meet the requirements of the labor market and bridge the skill gap in this field. The Islamic financial industry has significantly grown attracting funds from all over the world and becoming a strong competitor to the conventional sector. Nevertheless, this growth has not been matched with the availability of qualified professionals. Hence, this new track will provide students with the necessary skills to academically and professionally prepare them to be able to handle the challenges faced by this dynamic field. Accordingly, the curriculum was developed using courses and teaching strategies which develop the students' analytical knowledge and skills.



Banking and Finance Program

Career Prospects

The program equips students with the necessary skills that qualify them for a variety of career paths/jobs in the market including, but not limited to:

- Financial analyst
- Banker
- Financial manager/officer
- Financial markets analyst
- Fund/Investment manager
- Financial advisor/consultant
- Financial planner
- Investment analyst
- Investment banker
- Insurance specialist/officer
- Real estate manager
- Stock broker
- Portfolio manager
- Bank manager/officer
- Development banks/Institutions officer
- Venture capital professionals
- Sharia compliant specialist (Students from the Islamic track)





Banking and Finance Program

Key Achievements

Participate in the tenth annual
Durham Islamic Finance **Summer**
School, UK

2016



2017

The Banking and Finance department has developed the **Accounting Program** and the **Islamic Finance Track**.

BNFN students won the 3rd place in the **CFA challenge competition**.
Saudi Arabia

2018

2019

DAH signed an agreement with Bahrain Institute of Banking and Finance to offer a **Diploma in Trading and Financial Market Analysis Level 5 (QCF -UK)**

BNFN Students were awarded for their outstanding investment research in the **CFA Research Institute Challenge competition**
Saudi Arabia

2020

2021

BNFN students won 1st place in the **Fintech competition 2021**,
Saudi Arabia



The program is accredited by the **National Commission of Academic Accreditation and Assessment (NCAAA)**.

2022

2023

BNFN students has been certified in **Trading and Financial Market** by **BIBF Bahrain**

Banking and Finance Program

Clubs



Riyali Club

Riyali Club is an initiative for universities, which aims to spread financial literacy among university students while imparting the needed skills that will help them to apply financial concepts in their daily lives.



DAH Sustainability Club

Sustainability Club is about environmental which focus about element change, climate change is a pressing global challenge that requires immediate attention and action from all sectors, including educational institutions like ours.

DAH Sustainability Club aims to establish a sustainable community in Saudi Arabia by embracing sustainable principles and strategies in the areas of social, environmental, energy, and economic sustainability.



DAH SUSTAINABILITY CLUB
نادي الإسـتدامة



Banking and Finance Program

Admission Requirements and Tuition Fees

Entry requirements

Programs	TOFEL Score	Required Certificate Percentage	Qudurat Test Score	Other Admission Requirement
Bachelor of Banking and Finance (Track)	500	80%	65%	None
Bachelor of Islamic Finance (Track)				

Tuition Fees

Tuition Fees	Regular Fees	Raiaa Scholarship	Elm Scholarship	DAH Scholarship
Credit Fee	2,700.00	2,160.00	1,890.00	1,620.00
Semester Fee	40,000.00	32,000.00	28,000.00	24,000.00

